

Complete Range of
Swiss Cutting Solutions

palbit[®]
TOOLING SOLUTIONS EXPERTS
SINCE 1916

PalbitUSA.com

PILOT
Precision Products

SAL
Swiss Automatic Lathes

SINCE 1916

SAL - SWISS AUTOMATIC LATHES

MAIN FEATURES

Palbit inserts are specially developed to suit the cutting conditions and Swiss automatic lathes. Our inserts are made of micro-grain carbide which results in maximum strength when considering hardness and wear resistance. All cutting edges are fully ground and exceptionally sharp. Furthermore, we have applied our latest PVD coating on these specific cutting geometries, to achieve excellent tool life with Palbit inserts.

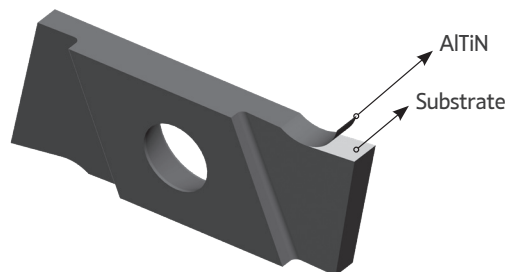
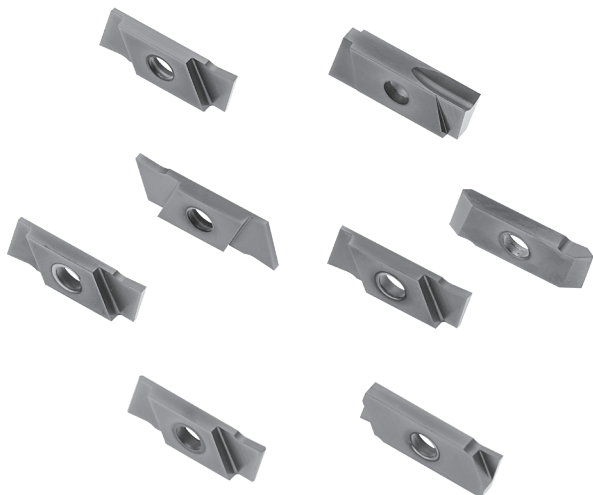

- PH7920**
- P10-P35
 - M10-M25
 - K15-K30
 - S10-S30

MULTIPLE INSERTS

Right toolholders and inserts style shown

Size
16 x 16 mm
0.625 x 0.625"

Size
12 x 12 mm
0.500 x 0.500"

Size
10 x 10 mm
0.375 x 0.375"

Size
8 x 8 mm
0.312 x 0.312"

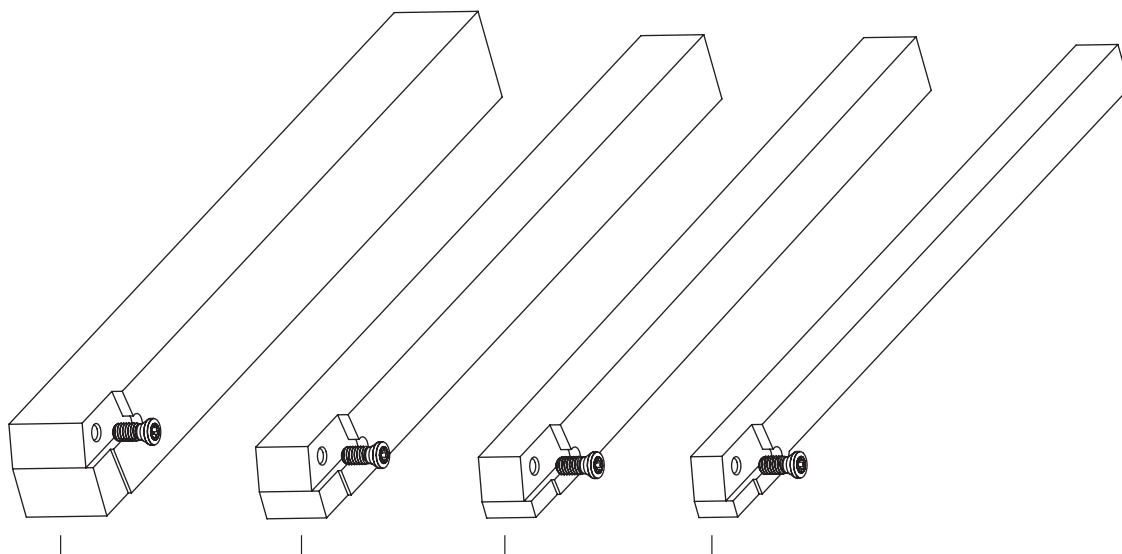

Select the toolholder and the insert. All inserts are compatible with all toolholders off the same side.



Grooving



Parting off



Threading



Turning

MAIN APPLICATIONS

INSERTS

4 Different operations:

- Turning
- Parting off
- Grooving
- Threading

TOOLHOLDERS

Dimensions:

- 08x08mm
- 10x10mm
- 12x12mm
- 16x16mm

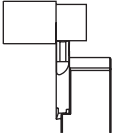

Turning

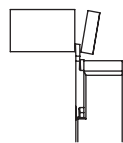
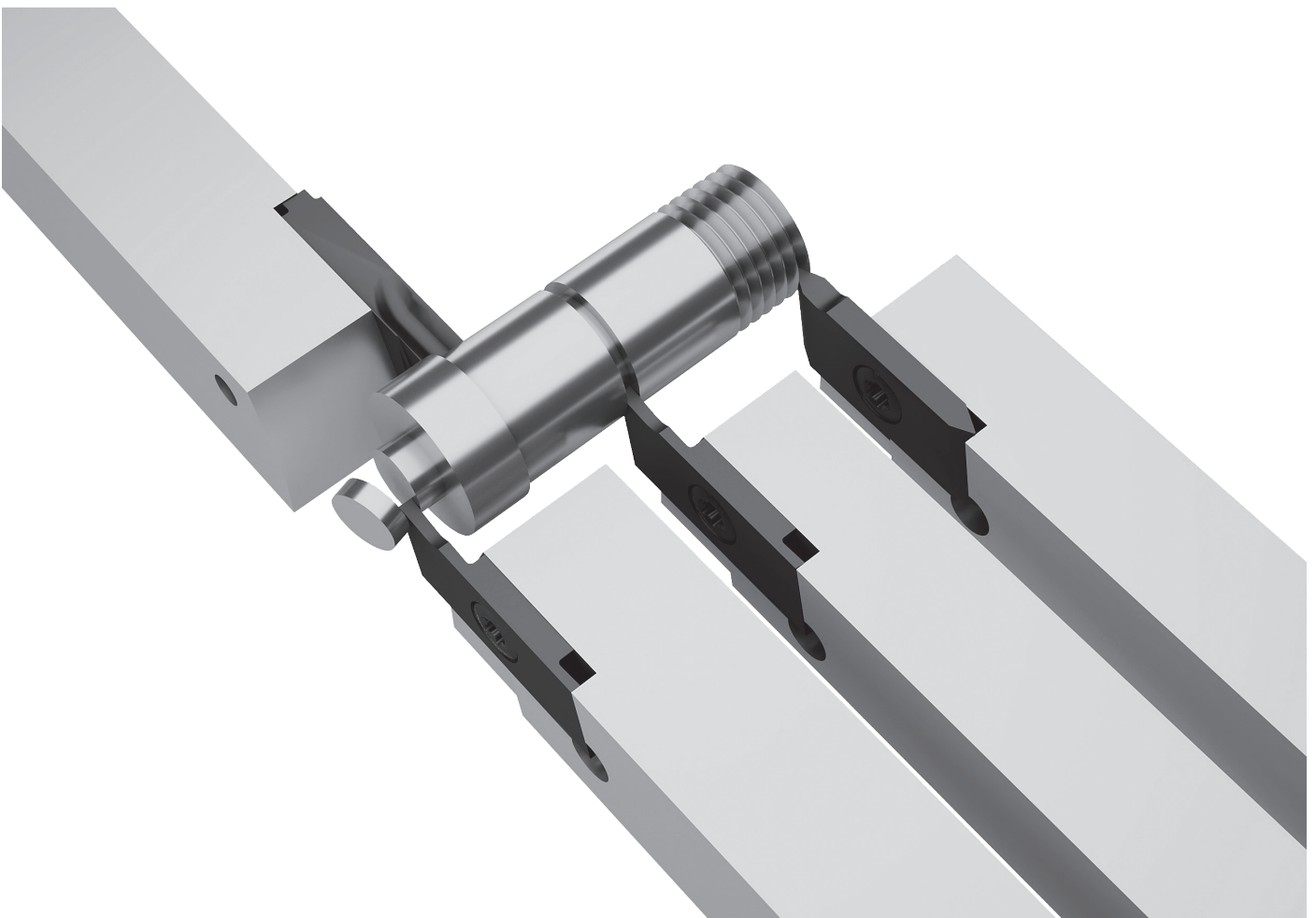

Parting off

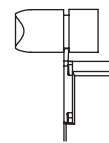

Grooving

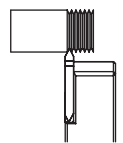

Threading

SAL - SWISS AUTOMATIC LATHES

INSERTS CODE KEY

Grooving Inserts					
SAL	25	G	050	R	
1	2	5	6	8	-
					GS
					11

Parting Off Inserts					
SAL	11	P	100	R	N
1	3	5	6	8	9
					P07
					11

Threading Inserts					
SAL	100	H	010	R	60
1	4	5	7	8	10
					PT
					11

Turning Inserts					
SAL	60	T	300	R	
1	2	5	6	8	-
					TP
					11

1 - Product Line
SAL - Swiss Automatic Lathes Line

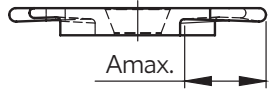
2 - Maximum Depth of Cut (Turning and Grooving Inserts)
25 - 2.5mm 60 - 6.0mm

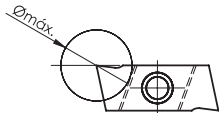

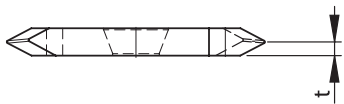
3 - Maximum Cutting Diameter (Parting Off Inserts)
11 - 11.0mm 13 - 13.0mm

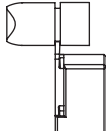
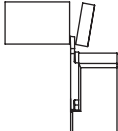
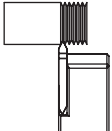
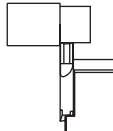

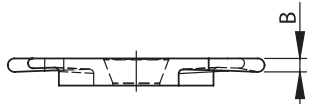
4 - Center Distance (Threading Inserts)
050 - 0.5mm 100 - 1.00mm

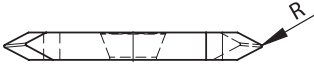
5 - Operations Type			
G - Grooving	P - Parting off	H - Threading	T - Turning
			

6 - Cut Thickness (Grooving, Parting Off and Turning Inserts)
050 - 0.50mm 070 - 0.70mm 080 - 0.80mm 090 - 0.90mm 100 - 1.00mm 110 - 1.10mm 130 - 1.30mm 150 - 1.50mm 160 - 1.60mm 185 - 1.85mm 200 - 2.00 mm 300 - 3.00 mm

7 - Corner Radius (Threading Inserts)
005 - 0.05mm 010 - 0.10mm 012 - 0.12mm

8 - Insert/Toolholder Side	
L - Left hand	R - Right hand
	

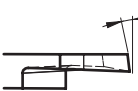
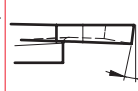
9 - Front Angle (Parting Off)		
N - Neutral	R - Right	L - Left
		

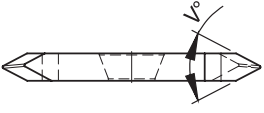
10 - Angle (Threading Inserts)
55 - 55° 60 - 60°

11 - Chip Breaker (Turning, Grooving, Parting Off and Threading Inserts)	
Turning	TP - Turning steel
Grooving	GS - Square Grooving GR - Round Grooving
Parting Off	P00 - Front angle 0° P07 - Front angle 7°
Threading	PT - Partial Profile

TOOLHOLDER CODE KEY

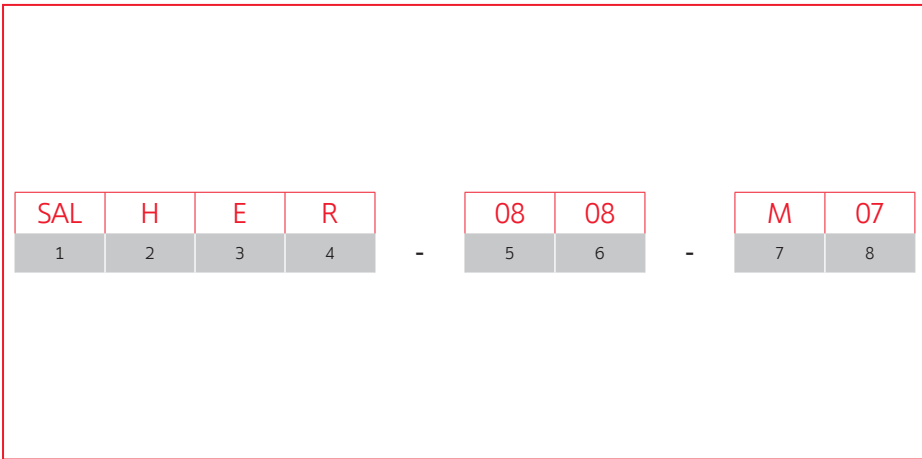

1 - Product Line
SAL - Swiss Automatic Lathes Line

2 - Tool Type
H - Holder

3 - Internal or External
E - External

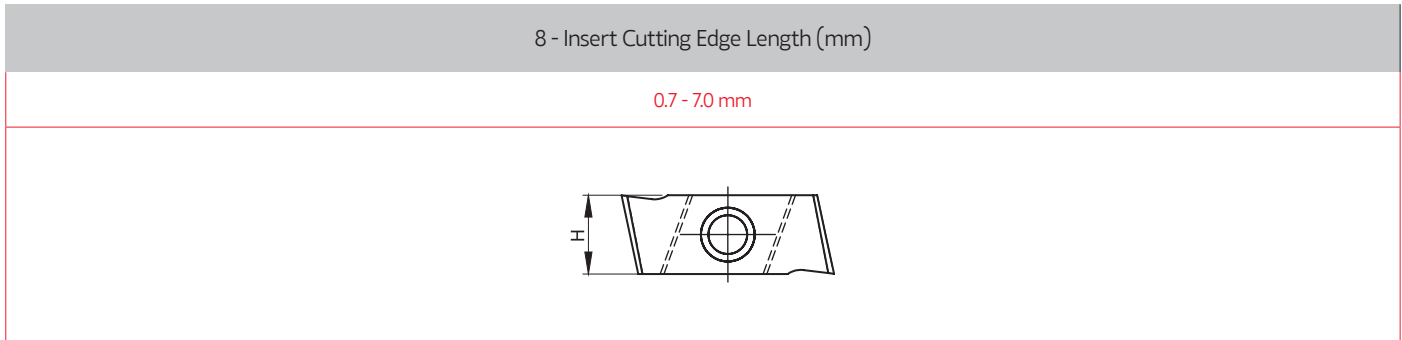
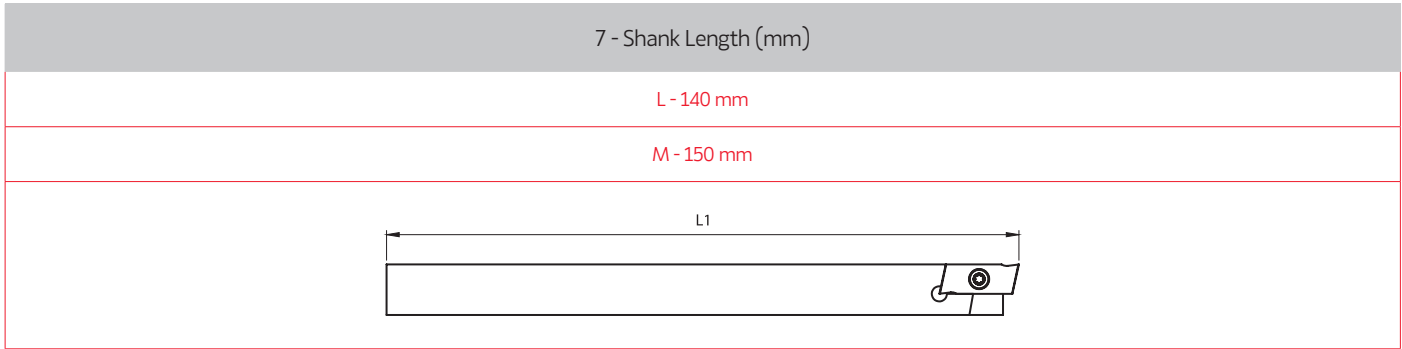
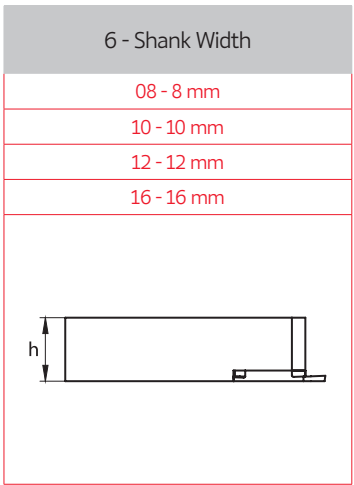
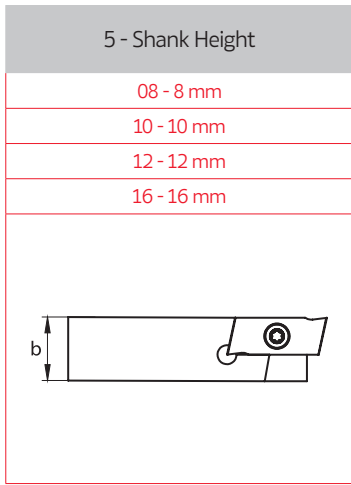
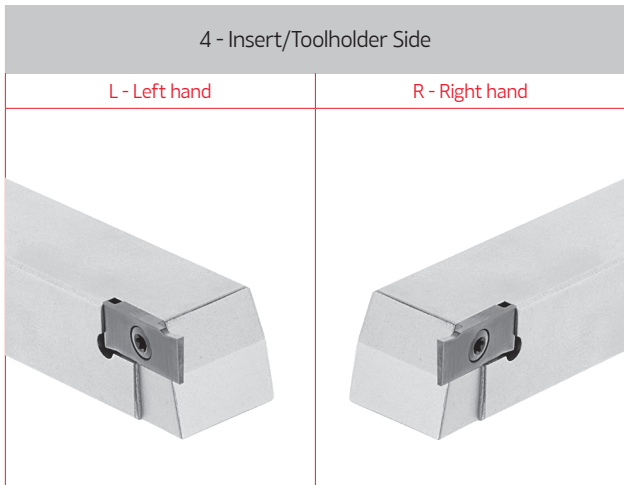

SAL - SWISS AUTOMATIC LATHES

EXTERNAL TOOLHOLDERS

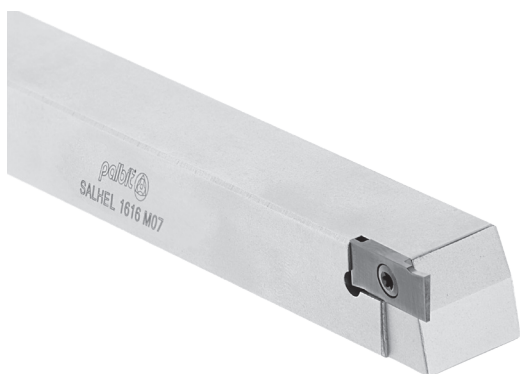

Left hand style shown

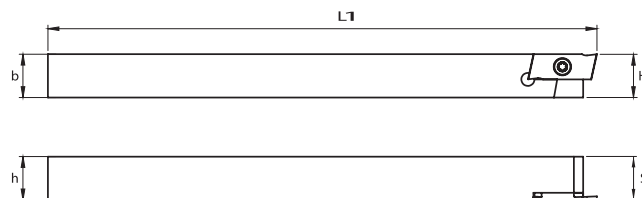

Order Code	Reference	Dimensions (mm)					* Insert	Screw	Wrench	Stock
		h	b	H	L1	S				
213023600	SALHEL 0808 M07	8.00	8.00	8.00	150.00	8.00	SAL...L	P0300900	XT 08	☺
213023700	SALHEL 1010 M07	10.00	10.00	10.00	150.00	10.00	SAL...L	P0300900	XT 08	☺
213023800	SALHEL 1212 M07	12.00	12.00	12.00	150.00	12.00	SAL...L	P0300900	XT 08	☺
213023900	SALHEL 1616 M07	16.00	16.00	16.00	150.00	16.00	SAL...L	P0300900	XT 08	☺
213029700	SALHEL 2020 M07	20.00	20.00	20.00	150.00	20.00	SAL...L	P0300900	XT 08	☺
213029900	SALHEL 2525 M07	25.00	25.00	25.00	150.00	25.00	SAL...L	P0300900	XT 08	☺

☺ Stock item

○ Available Upon Request

* Left insert only fits on left toolholder



Right hand style shown

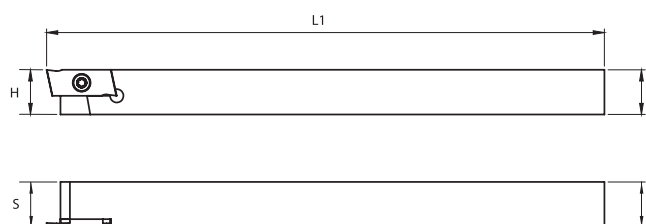

Order Code	Reference	Dimensions (mm)					* Insert	Screw	Wrench	Stock
		h	b	H	L1	S				
213023200	SALHER 0808 M07	8.00	8.00	8.00	150.00	8.00	SAL...R	P0300900	XT 08	☺
213023300	SALHER 1010 M07	10.00	10.00	10.00	150.00	10.00	SAL...R	P0300900	XT 08	☺
213023400	SALHER 1212 M07	12.00	12.00	12.00	150.00	12.00	SAL...R	P0300900	XT 08	☺
213023500	SALHER 1616 M07	16.00	16.00	16.00	150.00	16.00	SAL...R	P0300900	XT 08	☺
213029600	SALHER 2020 M07	20.00	20.00	20.00	150.00	20.00	SAL...R	P0300900	XT 08	☺
213029800	SALHER 2525 M07	25.00	25.00	25.00	150.00	25.00	SAL...R	P0300900	XT 08	☺

☺ Stock item

○ Available Upon Request

* Right insert only fits on right toolholder

GS SERIES

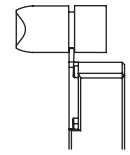
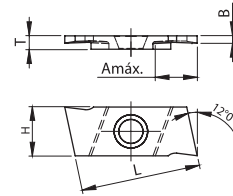

Right hand style shown. For square grooving.

Grooving

(1) Geometry Code	(2) Grade Code		PVD								Dimensions (mm)						Cutting Conditions			
			P M K S																	
			G1	G4	G4	P8	G4	P8	G4	P8	B	L	T	H	Amáx.	V°	Ømáx.	fn (mm/r)	Min.	Max.
1130441	SAL25G050R-GS	SAL25G050R-GS	○	⊗	⊗	○	⊗	○	⊗	○	0.50	17.00	2.00	7.00	2.50	-	-	0.04	0.02	0.06
1130475	SAL25G070R-GS	SAL25G070R-GS	○	⊗	⊗	○	⊗	○	⊗	○	0.70	17.00	2.00	7.00	2.50	-	-	0.05	0.02	0.08
1130477	SAL25G080R-GS	SAL25G080R-GS	○	⊗	⊗	○	⊗	○	⊗	○	0.80	17.00	2.00	7.00	2.50	-	-	0.05	0.02	0.09
1130479	SAL25G090R-GS	SAL25G090R-GS	○	⊗	⊗	○	⊗	○	⊗	○	0.90	17.00	2.00	7.00	2.50	-	-	0.06	0.02	0.10
1130488	SAL60G110R-GS	SAL60G110R-GS	○	⊗	⊗	○	⊗	○	⊗	○	1.10	17.00	2.00	7.00	6.00	-	-	0.06	0.02	0.11
1130490	SAL60G130R-GS	SAL60G130R-GS	○	⊗	⊗	○	⊗	○	⊗	○	1.30	17.00	2.00	7.00	6.00	-	-	0.07	0.02	0.12
1130442	SAL60G160R-GS	SAL60G160R-GS	○	⊗	⊗	○	⊗	○	⊗	○	1.60	17.00	2.00	7.00	6.00	-	-	0.07	0.02	0.13
1130495	SAL60G185R-GS	SAL60G185R-GS	○	⊗	⊗	○	⊗	○	⊗	○	1.85	17.00	2.00	7.00	6.00	-	-	0.08	0.02	0.14
1130473	SAL25G050L-GS	SAL25G050L-GS	○	⊗	⊗	○	⊗	○	⊗	○	0.50	17.00	2.00	7.00	2.50	-	-	0.04	0.02	0.06
1130474	SAL25G070L-GS	SAL25G070L-GS	○	⊗	⊗	○	⊗	○	⊗	○	0.70	17.00	2.00	7.00	2.50	-	-	0.05	0.02	0.08
1130476	SAL25G080L-GS	SAL25G080L-GS	○	⊗	⊗	○	⊗	○	⊗	○	0.80	17.00	2.00	7.00	2.50	-	-	0.05	0.02	0.09
1130478	SAL25G090L-GS	SAL25G090L-GS	○	⊗	⊗	○	⊗	○	⊗	○	0.90	17.00	2.00	7.00	2.50	-	-	0.06	0.02	0.10
1130487	SAL60G110L-GS	SAL60G110L-GS	○	⊗	⊗	○	⊗	○	⊗	○	1.10	17.00	2.00	7.00	6.00	-	-	0.06	0.02	0.11
1130489	SAL60G130L-GS	SAL60G130L-GS	○	⊗	⊗	○	⊗	○	⊗	○	1.30	17.00	2.00	7.00	6.00	-	-	0.07	0.02	0.12
1130493	SAL60G160L-GS	SAL60G160L-GS	○	⊗	⊗	○	⊗	○	⊗	○	1.60	17.00	2.00	7.00	6.00	-	-	0.07	0.02	0.13
1130494	SAL60G185L-GS	SAL60G185L-GS	○	⊗	⊗	○	⊗	○	⊗	○	1.85	17.00	2.00	7.00	6.00	-	-	0.08	0.02	0.14

⊗ Stock item

○ Available Upon Request. Delivery Time 4 Weeks.

Order Code = (1) Geometry Code + (2) Grade Code

GR SERIES

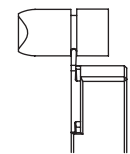
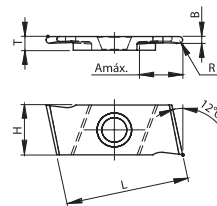
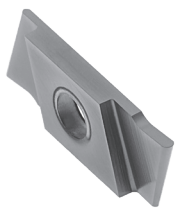

Right hand style shown. For square grooving.

Grooving

(1) Geometry Code	(2) Grade Code		PVD								Dimensions (mm)						Cutting Conditions			
			P M K S																	
			G1	G4	G4	P8	G4	P8	G4	P8	B	L	T	H	Amáx.	V°	Ømáx.	fn (mm/r)	Min.	Max.
1130443	SAL60G100R-GR	SAL60G100R-GR	○	⊗	⊗	○	⊗	○	⊗	○	1.00	17.00	2.00	7.00	6.00	-	-	0.06	0.02	0.10
1130492	SAL60G150R-GR	SAL60G150R-GR	○	⊗	⊗	○	⊗	○	⊗	○	1.50	17.00	2.00	7.00	6.00	-	-	0.08	0.02	0.12
1130497	SAL60G200R-GR	SAL60G200R-GR	○	⊗	⊗	○	⊗	○	⊗	○	2.00	17.00	2.00	7.00	6.00	-	-	0.08	0.03	0.14
1130486	SAL60G100L-GR	SAL60G100L-GR	○	⊗	⊗	○	⊗	○	⊗	○	1.00	17.00	2.00	7.00	6.00	-	-	0.06	0.02	0.10
1130491	SAL60G150L-GR	SAL60G150L-GR	○	⊗	⊗	○	⊗	○	⊗	○	1.50	17.00	2.00	7.00	6.00	-	-	0.08	0.02	0.12
1130496	SAL60G200L-GR	SAL60G200L-GR	○	⊗	⊗	○	⊗	○	⊗	○	2.00	17.00	2.00	7.00	6.00	-	-	0.08	0.03	0.14

⊗ Stock item

○ Available Upon Request. Delivery Time 4 Weeks.

Order Code = (1) Geometry Code + (2) Grade Code

SAL - SWISS AUTOMATIC LATHES

P(P00) SERIES

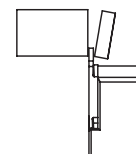
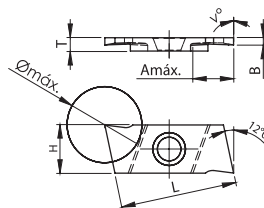
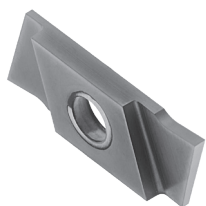

Right hand style shown. Without front angle.

Parting off

(1) Geometry Code	(2) Grade Code		PVD								Dimensions (mm)						Cutting Conditions			
			PVD																	
			G1	G4	G4	P8	G4	P8	G4	P8	B	L	T	H	Amáx.	V°	Ømáx.	fn (mm/r)	Min.	Max.
1130444	SAL11P100RN-P00	SAL11P100RN-P00	○	⊗	⊗	○	⊗	○	⊗	○	1.00	17.00	2.00	7.00	6.00	0	11.00	0.06	0.02	0.10
1130462	SAL11P150RN-P00	SAL11P150RN-P00	○	⊗	⊗	○	⊗	○	⊗	○	1.50	17.00	2.00	7.00	6.00	0	11.00	0.08	0.02	0.12
1130468	SAL13P200RN-P00	SAL13P200RN-P00	○	⊗	⊗	○	⊗	○	⊗	○	2.00	17.00	2.00	7.00	6.00	0	13.00	0.08	0.03	0.14
1130456	SAL11P100LN-P00	SAL11P100LN-P00	○	⊗	⊗	○	⊗	○	⊗	○	1.00	17.00	2.00	7.00	6.00	0	11.00	0.06	0.02	0.10
1130459	SAL11P150LN-P00	SAL11P150LN-P00	○	⊗	⊗	○	⊗	○	⊗	○	1.50	17.00	2.00	7.00	6.00	0	11.00	0.08	0.02	0.12
1130465	SAL13P200LN-P00	SAL13P200LN-P00	○	⊗	⊗	○	⊗	○	⊗	○	2.00	17.00	2.00	7.00	6.00	0	13.00	0.08	0.03	0.14

⊗ Stock item

○ Available Upon Request. Delivery Time 4 Weeks.

Order Code = (1) Geometry Code + (2) Grade Code

P(P07) SERIES

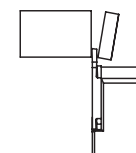
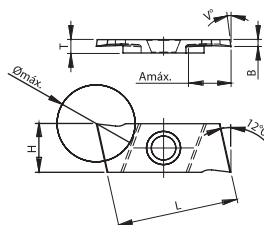
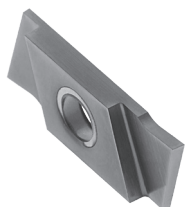

Right hand style shown. Front angle 7°.

Parting off

(1) Geometry Code	(2) Grade Code		PVD								Dimensions (mm)						Cutting Conditions			
			PVD																	
			G1	G4	G4	P8	G4	P8	G4	P8	B	L	T	H	Amáx.	V°	Ømáx.	fn (mm/r)	Min.	Max.
1130445	SAL11P100RR-P07	SAL11P100RR-P07	○	⊗	⊗	○	⊗	○	⊗	○	1.00	17.00	2.00	7.00	6.00	7	11.00	0.05	0.02	0.08
1130446	SAL11P100RL-P07	SAL11P100RL-P07	○	⊗	⊗	○	⊗	○	⊗	○	1.00	17.00	2.00	7.00	6.00	7	11.00	0.05	0.02	0.08
1130463	SAL11P150RR-P07	SAL11P150RR-P07	○	⊗	⊗	○	⊗	○	⊗	○	1.50	17.00	2.00	7.00	6.00	7	11.00	0.06	0.02	0.10
1130461	SAL11P150RL-P07	SAL11P150RL-P07	○	⊗	⊗	○	⊗	○	⊗	○	1.50	17.00	2.00	7.00	6.00	7	11.00	0.06	0.02	0.10
1130469	SAL13P200RR-P07	SAL13P200RR-P07	○	⊗	⊗	○	⊗	○	⊗	○	2.00	17.00	2.00	7.00	6.00	7	13.00	0.06	0.03	0.12
1130467	SAL13P200RL-P07	SAL13P200RL-P07	○	⊗	⊗	○	⊗	○	⊗	○	2.00	17.00	2.00	7.00	6.00	7	13.00	0.06	0.03	0.12
1130457	SAL11P100LR-P07	SAL11P100LR-P07	○	⊗	⊗	○	⊗	○	⊗	○	1.00	17.00	2.00	7.00	6.00	7	11.00	0.05	0.02	0.08
1130455	SAL11P100LL-P07	SAL11P100LL-P07	○	⊗	⊗	○	⊗	○	⊗	○	1.00	17.00	2.00	7.00	6.00	7	11.00	0.05	0.02	0.08
1130460	SAL11P150LR-P07	SAL11P150LR-P07	○	⊗	⊗	○	⊗	○	⊗	○	1.50	17.00	2.00	7.00	6.00	7	11.00	0.06	0.02	0.10
1130458	SAL11P150LL-P07	SAL11P150LL-P07	○	⊗	⊗	○	⊗	○	⊗	○	1.50	17.00	2.00	7.00	6.00	7	11.00	0.06	0.02	0.10
1130466	SAL13P200LR-P07	SAL13P200LR-P07	○	⊗	⊗	○	⊗	○	⊗	○	2.00	17.00	2.00	7.00	6.00	7	13.00	0.06	0.03	0.12
1130464	SAL13P200LL-P07	SAL13P200LL-P07	○	⊗	⊗	○	⊗	○	⊗	○	2.00	17.00	2.00	7.00	6.00	7	13.00	0.06	0.03	0.12

⊗ Stock item

○ Available Upon Request. Delivery Time 4 Weeks.

Order Code = (1) Geometry Code + (2) Grade Code

PT SERIES

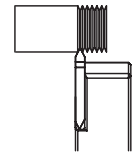
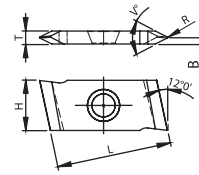

Right hand style shown. For partial profile threading.

Threading

(1) Geometry Code	(2) Grade Code		PVD								Dimensions (mm)						Cutting Conditions				
			P		M		K		S												
			G1	G4	G4	P8	G4	P8	G4	P8	B	L	T	H	Amáx.	V°	Ømáx.	fn (mm/r)	Min.	Max.	
1130472	SAL100H012R55-PT	SAL100H012R55-PT	○	⊗	⊗	○	⊗	○	⊗	○	○	1.09	1700	2.00	7.00	0.12	55	-	0.80	0.20	2.00
1130447	SAL100H012R60-PT	SAL100H012R60-PT	○	⊗	⊗	○	⊗	○	⊗	○	○	1.09	1700	2.00	7.00	0.12	60	-	0.80	0.20	2.00
1130470	SAL100H012L55-PT	SAL100H012L55-PT	○	⊗	⊗	○	⊗	○	⊗	○	○	1.09	1700	2.00	7.00	0.12	55	-	0.80	0.20	2.00
1130471	SAL100H012L60-PT	SAL100H012L60-PT	○	⊗	⊗	○	⊗	○	⊗	○	○	1.09	1700	2.00	7.00	0.12	60	-	0.80	0.20	2.00

⊗ Stock item

○ Available Upon Request. Delivery Time 4 Weeks.

Order Code = (1) Geometry Code + (2) Grade Code

TP SERIES

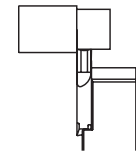
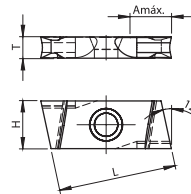
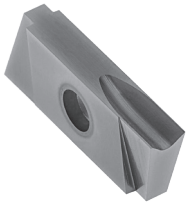

Right hand style shown. For turning.

Turning

(1) Geometry Code	(2) Grade Code		PVD								Dimensions (mm)						Cutting Conditions			
			P		M		K		S											
			G1	G4	G4	P8	G4	P8	G4	P8	B	L	T	H	Amáx.	V°	Ømáx.	fn (mm/r)	Min.	Max.
1130501	SAL60T300R-TP	SAL60T300R-TP	○	⊗	⊗	○	⊗	○	⊗	○	-	1700	3.17	7.00	6.00	-	-	0.08	0.02	0.12
1130499	SAL60T300L-TP	SAL60T300L-TP	○	⊗	⊗	○	⊗	○	⊗	○	-	1700	3.17	7.00	6.00	-	-	0.08	0.02	0.12

⊗ Stock item

○ Available Upon Request. Delivery Time 4 Weeks.

Order Code = (1) Geometry Code + (2) Grade Code

BLANKS FOR GRINDING

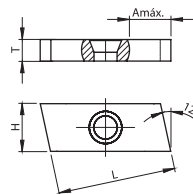

Right hand style shown

Inserts blanks “do it yourself” grinding are available, allowing for insert modifications for any machining operation.

(1) Geometry Code	(2) Grade Code		Uncoated			Dimensions (mm)						
			10	12	14							
			PH0910	PH0920	PH0135	B	L	T	H	Amáx.	V°	Ømáx.
1130440	BLANK SALR 17x7x2	BLANK SALR 17x7x2	⊗	⊗	⊗	-	1750	2.00	750	-	-	-
1130504	BLANK SALR 17x7x3,17	BLANK SALR 17x7x3,17	⊗	⊗	⊗	-	1750	3.17	750	-	-	-
1130453	BLANK SALL 17x7x2	BLANK SALL 17x7x2	⊗	⊗	⊗	-	1750	2.00	750	-	-	-
1130505	BLANK SALL 17x7x3,17	BLANK SALL 17x7x3,17	⊗	⊗	⊗	-	1750	3.17	750	-	-	-

⊗ Stock item

○ Available Upon Request

Order Code = (1) Geometry Code + (2) Grade Code

SAL - SWISS AUTOMATIC LATHES

GROOVING

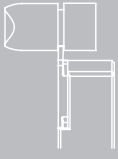

- High Precision
- Close Tolerances
- Wide Variety of Insert Widths

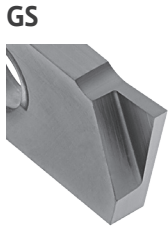

Square grooving

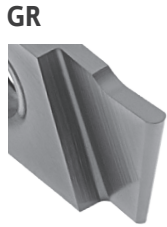

Round grooving

Recommended Cutting Conditions

P	M	K	S
60-200	60-180	60-150	20-50

Recommended grade PH7920, (Vc) m/min.

Grade PH7910 and PH7135

Available Upon Request

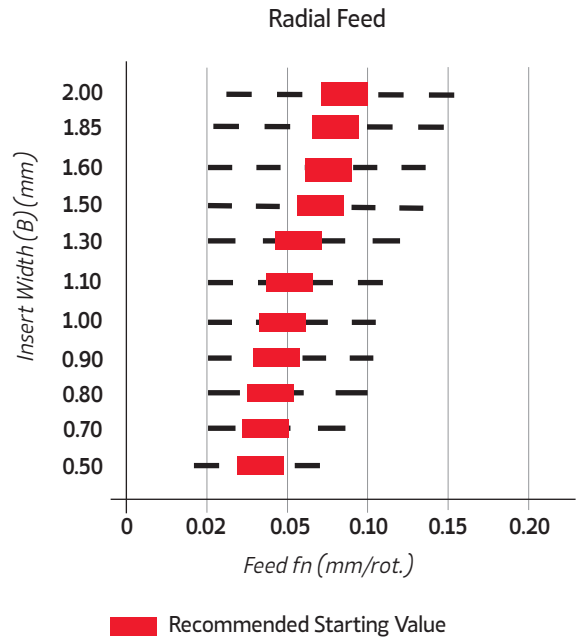

PARTING OFF



- When parting off with a sub-spindle, it is more productive to use a straight cutting edge. This is a more stable parting method and will generate the best surface finish.
- When parting off without a sub-spindle, we recommend you use an insert with a maximum 7° front angle to minimize the risk of burr and pips on the component.
- When parting off with 7° front angled inserts, we recommend reducing the feed rate by approximately 30%.

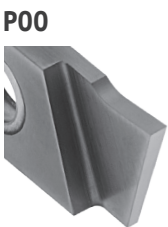

0° Relief angle

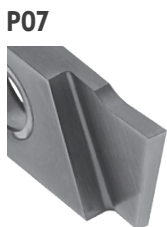

7° Relief angle

Recommended Cutting Conditions

P	M	K	S
60-200	60-180	60-150	20-50

Recommended grade PH7920, (Vc) m/min.

Grade PH7910 and PH7135

Available Upon Request (4 weeks delivery time)

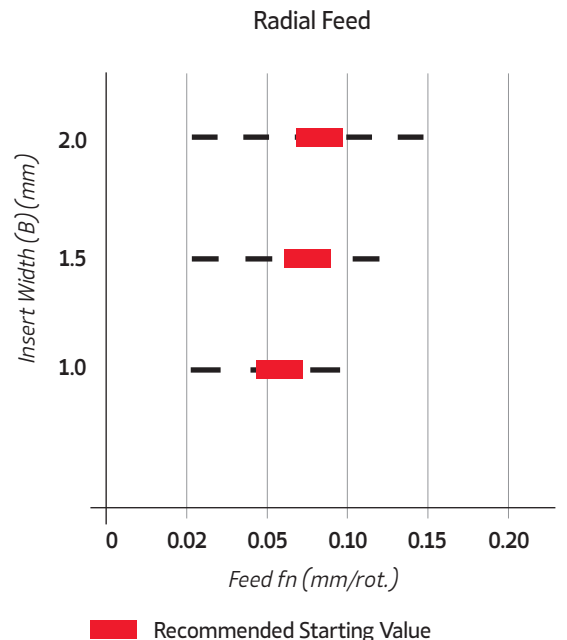

THREADING

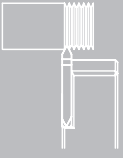

Two types of threading:

- Partial Profile 55°
- Partial Profile 60°

Pitch from 12-94 TPI / 0.25 - 2.0 mm

PT



Partial profile

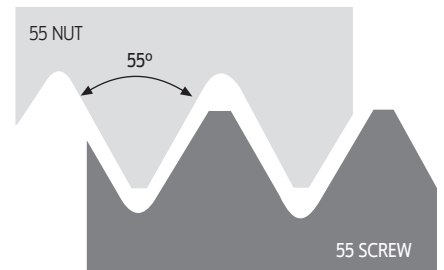
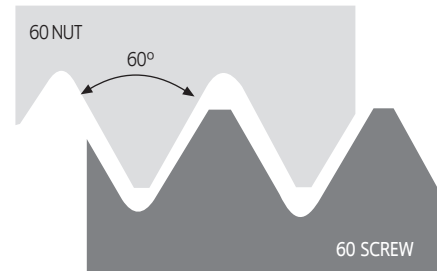

Recommended Cutting Conditions

P	M	K	S
60-200	60-180	60-150	20-50

Recommended grade PH7920, (Vc) m/min.

Grade PH7910 and PH7135

Available Upon Request (Delivery Time of 4 Weeks)

TURNING

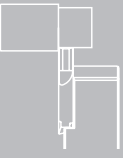

- Insert for Turning
- Maximum Depth of Cut is 2.50 mm
- Too low a cutting speed will result in inadequate tool life. Therefore, it is advisable to follow cutting speed recommendations.

TP

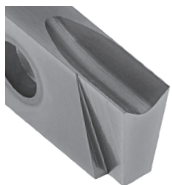

Turning steel

Recommended Cutting Conditions

P	M	K	S
60-200	60-180	60-150	20-50

Recommended grade PH7920, (Vc) m/min.

Grade PH7910 and PH7135

Available Upon Request (Delivery Time of 4 Weeks)

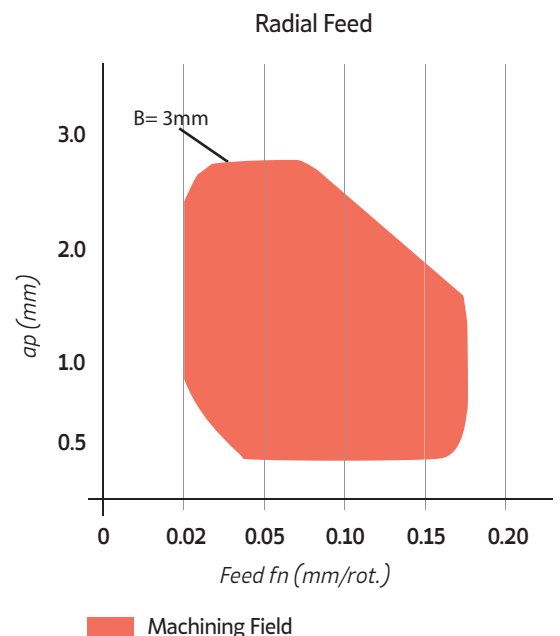

SAL - SWISS AUTOMATIC LATHES

TEST REPORT 01

P00

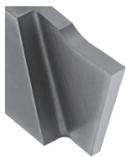

0° Front angle

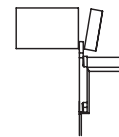

Parting off

<p>Toolholder SALHER 1212 M07</p> <p>Insert SAL11P100RN - P00</p> <p>Grade PH7920</p> <p>20% productivity improvement</p> <p>Number of pieces 12 000</p> <p>palbit CUTTING TOOL SOLUTIONS</p>	<p>Toolholder Competitor Equivalent Product</p> <p>Insert Competitor Equivalent Product</p> <p>Grade Competitor Equivalent Product</p> <p>Number of pieces 10 000</p> <p>COMPETITOR</p>
--	--

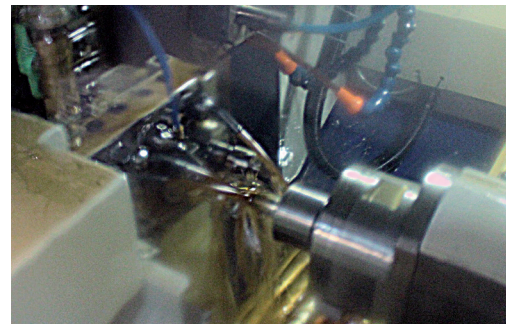

Work material: AISI 316

Cutting speed: Vc (m/min)	100
Feed per tooth: fn (mm/r)	0,08
Diameter (mm)	10
Machining method	Parting off
Coolant	Yes

TEST REPORT 02

GS

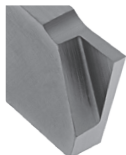

Insert for square grooving

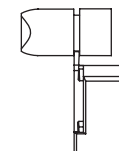

Grooving

<p>Toolholder SALHER 1616 M07</p> <p>Insert SAL25G080R - GS</p> <p>Grade PH7920</p> <p>25% productivity improvement</p> <p>Number of pieces 10 000</p> <p>palbit CUTTING TOOL SOLUTIONS</p>	<p>Toolholder Competitor Equivalent Product</p> <p>Insert Competitor Equivalent Product</p> <p>Grade Competitor Equivalent Product</p> <p>Number of pieces 8 000</p> <p>COMPETITOR</p>
--	---



Work material: 34CrNiMo6

Cutting speed: Vc (m/min)	120
Feed per tooth: fn (mm/r)	0,05
Diameter (mm)	8
Machining method	Grooving
Coolant	Yes

PILOT_PALBIT_FYMKKT_26_ED000_REV04 (22)