

Tooling solutions for Mould & Die

Precision tools from roughing to finishing



MOULD & DIE



PalbitUSA.com



MOULD & DIE

NEW



PDF



VIDEO

Precision tools **from roughing to finishing**

Mould & Die industry requires considerable metal working skills because of the amount of applications (injection moulds, stamping moulds, pressing dies, forging & casting dies and moulds) and the variety of material types (steels, hardened steels, aluminiums and non-ferrous, and cast irons).

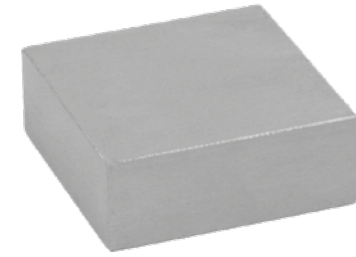

STEEL BLOCK



INJECTION
MOULD

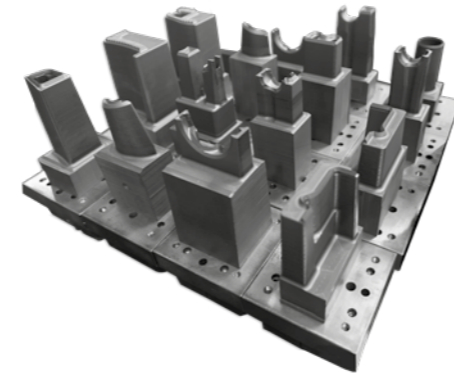

GRAPHITE
ELETRODES

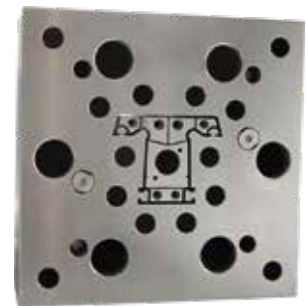

SUPPORT PLATE

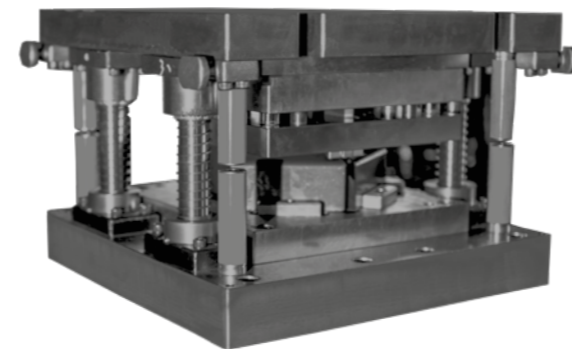

STAMPING
MOULDS

As an experienced manufacturer of milling solutions, Palbit has become a first-class supplier of plate machining solutions. With a broad range of solutions, at Palbit always finds innovative ways to boost our client's productivity.



PLUS 90945 | 91245
Ø50 - Ø250

Palbit has a wide range of high feed milling solutions. From Ø10 to Ø160 and solutions for every type of material, Palbit has a solution for every challenge.

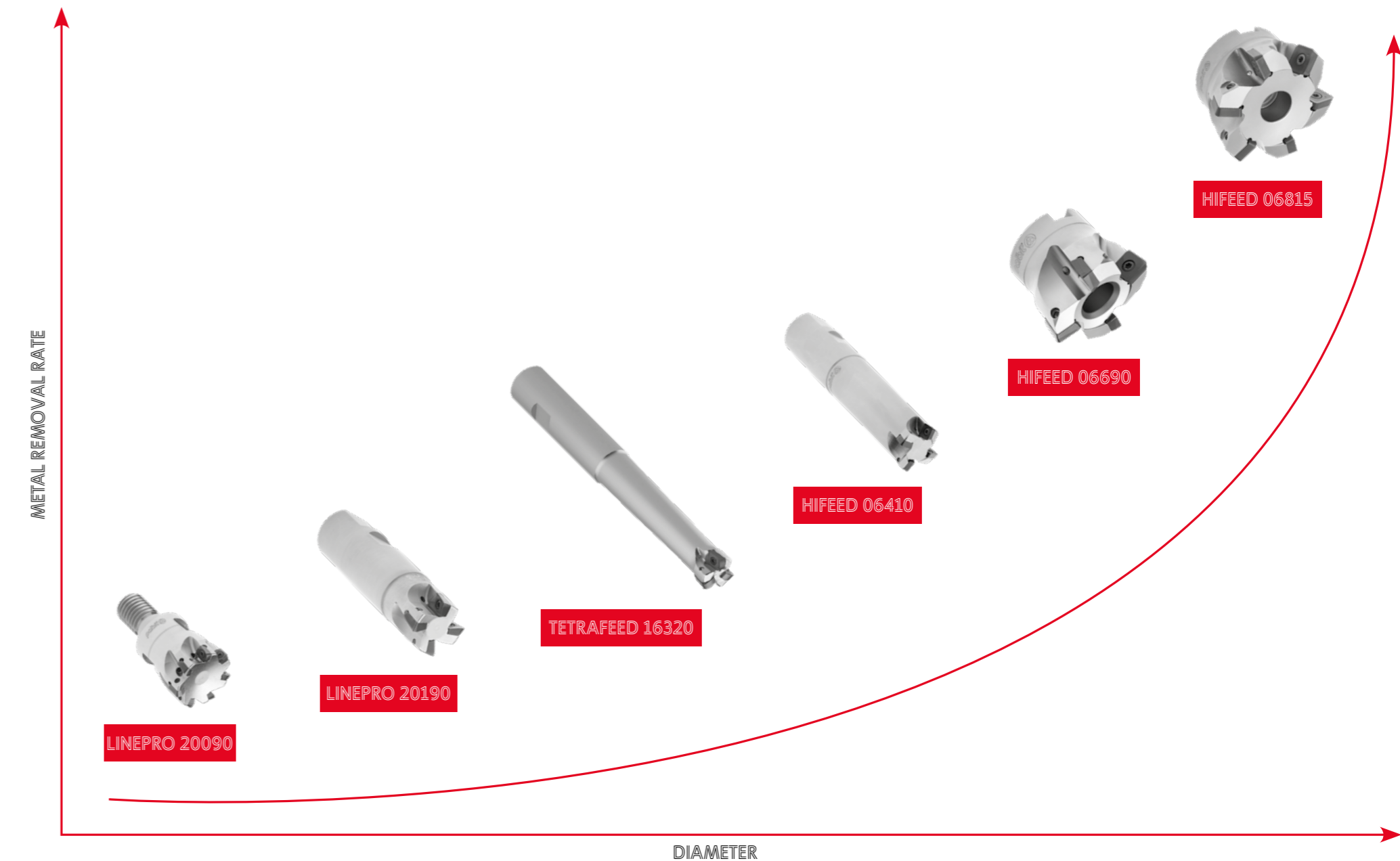
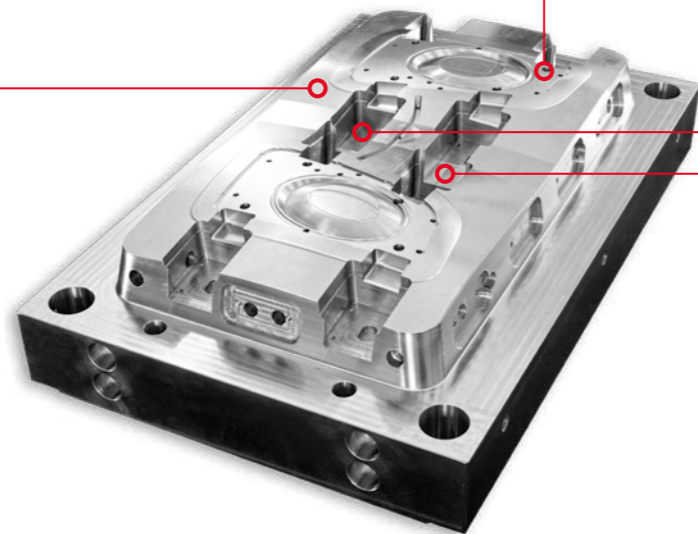

DEEP CAVITY ROUGHING | Maquinação de cavidades profundas | Mecanizado de cavidades profundas

For deep cavities machining, tools with high overhang must be used. TETRAFEED 16320 works remarkably well in deep cavities using high feeds. Palbit's HIFEED 50060 can work extreme overhangs (>20D).

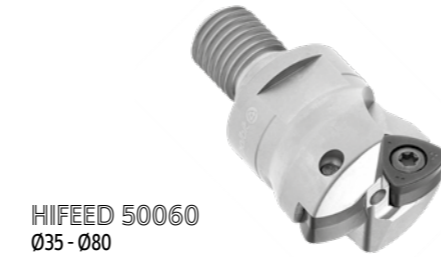
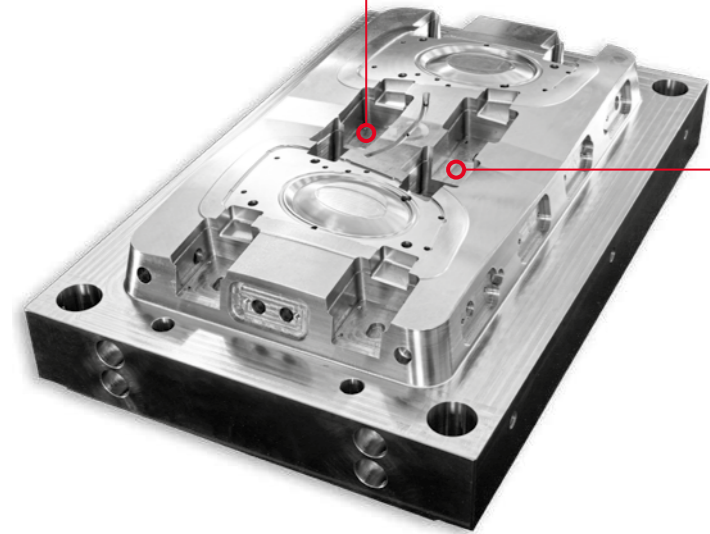

HIFEED 50060
Ø35 - Ø80



TETRAFEED 16320
Ø16 - Ø63

SHOULDERING | Maquinação a 90° | Operaciones de Escuadrar

Palbit has a vast selection of shouldering/slotting cutters for every mould and die application.



PLUS 17190
Ø14 - Ø100

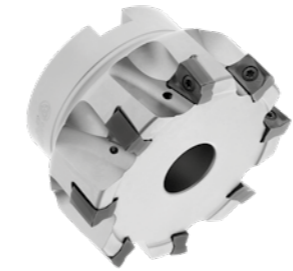

PLUS 17590
Ø25 - Ø125

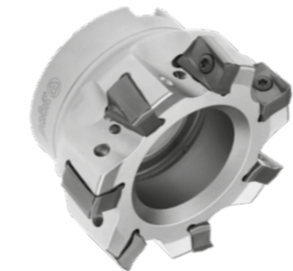

PLUS 18190
Ø32 - Ø160



DYN-INTEG
Ø4 - Ø20

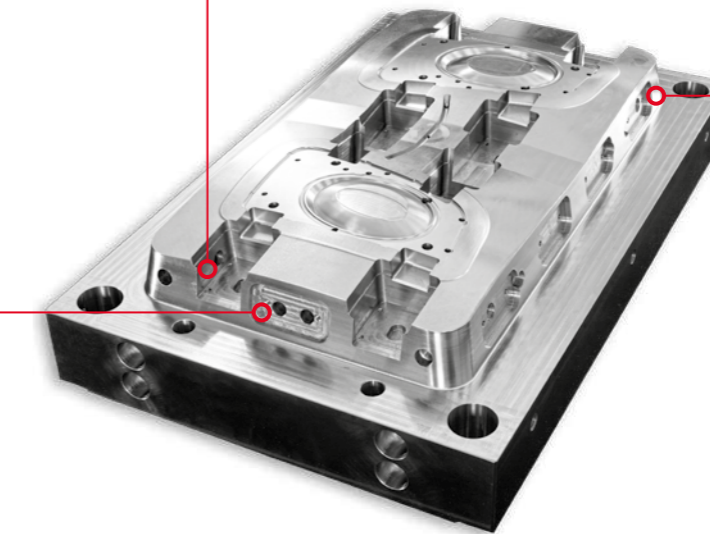

LINEPRO 20090
Ø10 - Ø32

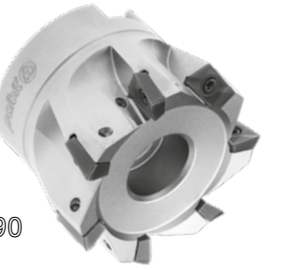

LINEPRO 20190
Ø16 - Ø63



LINEPRO 20290
Ø32 - Ø125

Finishing operations are crucial for the quality of the final product. Palbit offers a versatile set of finishing solutions from indexable milling to integral solid carbide endmills.



W-PRO 62090
Ø8 - Ø20



FIN-INTEG
Ø4 - Ø20



PLUS 49095 | 45095
Ø16 - Ø42



CENTER & CHAMFER



RAD-INTEG
Ø6 - Ø16

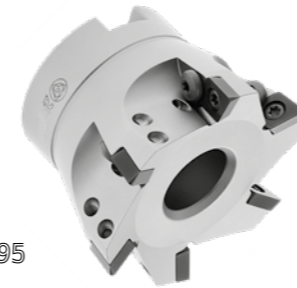
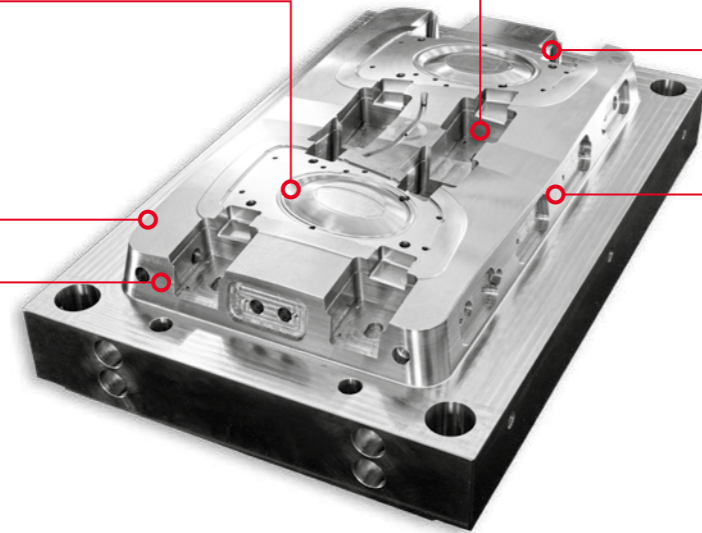

LINEPRO 40095
Ø16 - Ø25

From coolant channels, guide holes, etc., Mould and die components have a vast number of holes. Palbit offers a large range of drilling solutions.



JET DRILLS
Ø12 - Ø80



INTEGREX DRILLS
Ø18 - Ø80



SPOT FACE
Ø10 - Ø21

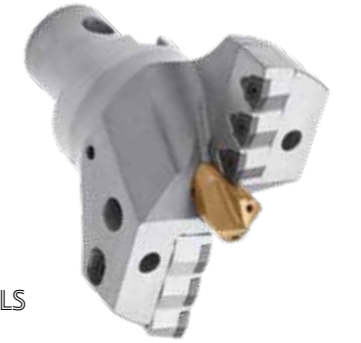
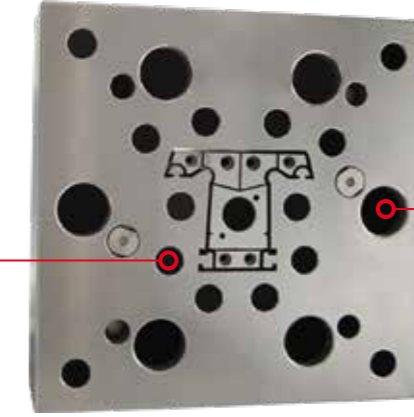

VORTEX DRILLS
Ø45 - Ø180

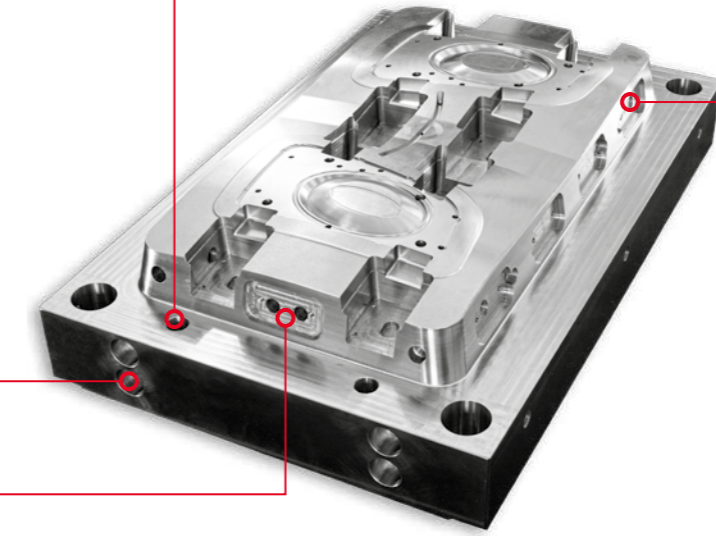

SOLID CARBIDE DRILLS
Ø3 - Ø20

The EDM process is widely used by the mould and die. To machine graphite electrodes Palbit has standard PCD tipped solutions and special PCD coated endmills.

PCD TIPPED ENDMILLS
Ø3 - Ø16



DIAMOND COATED ENDMILLS
Ø2 - Ø10



LINEPRO 40595|40095|41095
Ø10 - Ø80

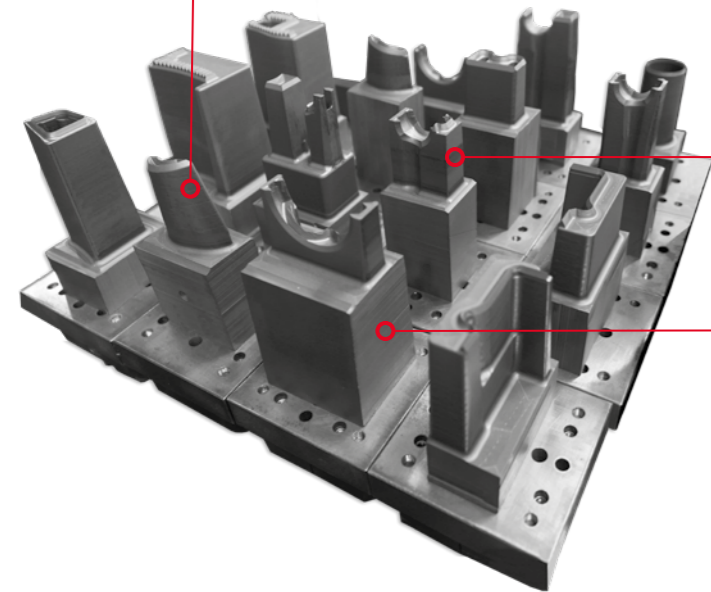

Stamping moulds require flawless wall surface quality. Palbit tools deliver such quality with superb accuracy.

TETRAFEED 16320
Ø16 - Ø63



W-PRO 62090
Ø8 - Ø20



SOLID CARBIDE DRILLS
Ø3 - Ø20



FIN-INTEG
Ø4 - Ø20



JET DRILLS
Ø12 - Ø80

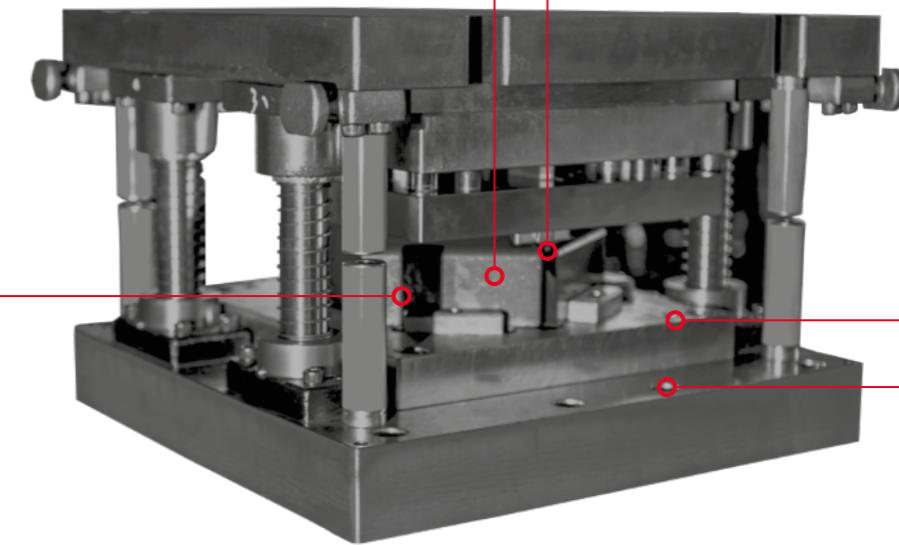



PalbitUSA.com



MOULD & DIE

NEW

TOOLING SOLUTIONS FOR MOULD & DIE

SINCE 1916



MOULD & DIE

U.S. Partner:



15 Merrigan Way | South Deerfield, MA 01373

413-350-5200 | PilotPrecision.com

ISO 9001:2015

