

# High Productivity for Cylindrical Surfaces



PalbitUSA.com

**PILOT**  
Precision Products

**BAR PEELING**  
Tool Solutions



SINCE 1916

# BAR PEELING



BAR PEELING

Bar Peeling is the machining process by which a raw forged blank is converted into a polished bar. During the peeling process, surface cracks and oxide layers are removed, giving the bar a perfect roundness with good surface and dimensional accuracy.

The range of materials that can be machined with these tools is vast and goes from all kinds of Steels to Cast Iron parts.

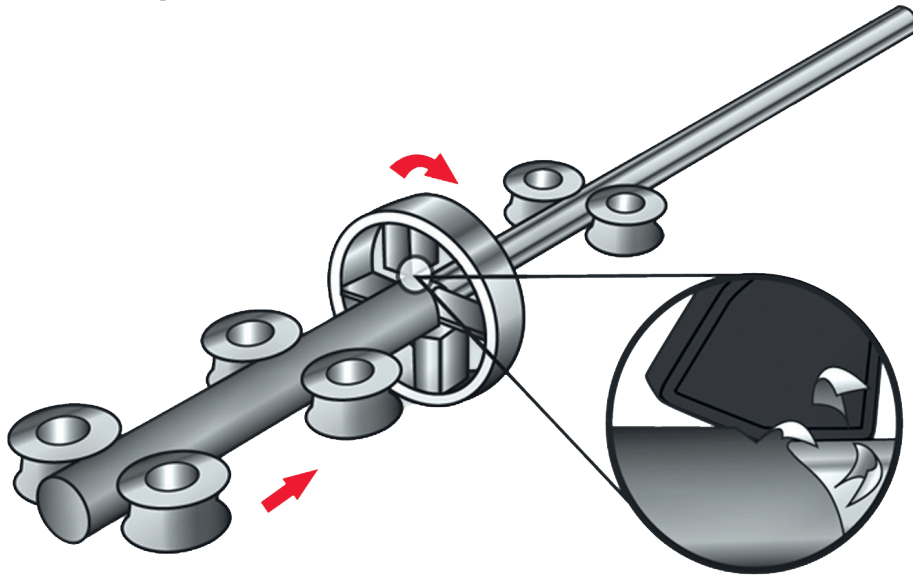

The size of a blank bar can range from 4 mm (.157 in.) to more than 400 mm (15.75 in.) in diameter.

The surface quality and dimensional tolerances are also high, which leads to less machining at later stages.

Our aim is to improve your productivity (by removing maximal chip volume) while meeting or exceeding your surface quality requirements. That is why our Bar Peeling Program is comprehensive and includes standard tools and custom solutions.

This brochure describes only a small portion of our production capabilities. Please don't hesitate to contact us regarding other possible geometries.

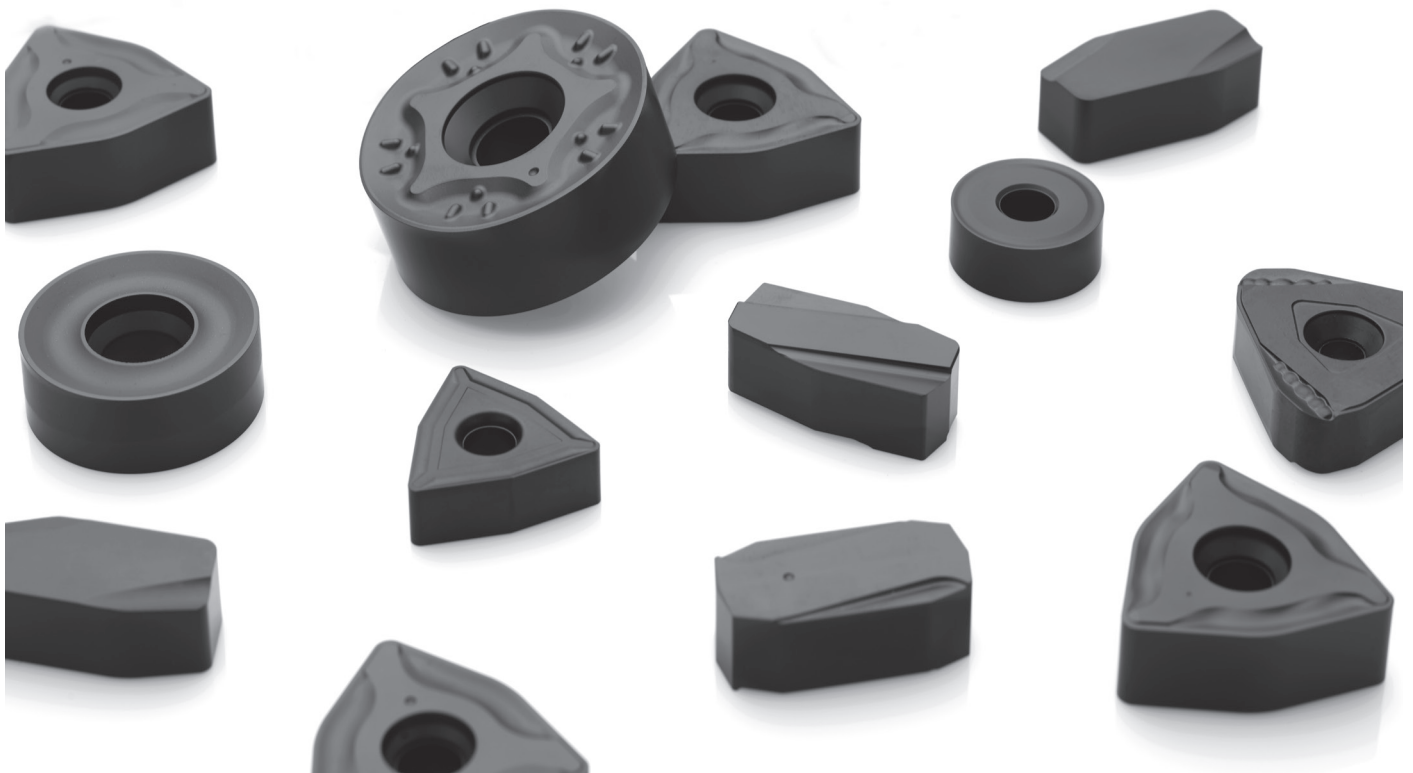

# CODE KEY

|          |          |          |          |           |           |           |   |           |
|----------|----------|----------|----------|-----------|-----------|-----------|---|-----------|
| <b>L</b> | <b>N</b> | <b>G</b> | <b>F</b> | <b>20</b> | <b>10</b> | <b>35</b> | - | <b>MP</b> |
| 1        | 2        | 3        | 4        | 5         | 6         | 7         |   | 8         |

| 1 - Insert Shape |          |           |           |          |
|------------------|----------|-----------|-----------|----------|
|                  |          |           |           |          |
| <b>I</b>         | <b>J</b> | <b>L</b>  | <b>R</b>  | <b>S</b> |
|                  |          |           |           |          |
| 60°              |          | 75° / 80° | 85° / 90° |          |
| <b>T</b>         | <b>U</b> | <b>W</b>  | <b>X</b>  |          |

| 2 - Clearance Angle |
|---------------------|
|                     |
| <b>N</b>            |

| 5 - Length of Cutting Edge (In)                             |              |
|---|--------------|
| The length of the secondary cutting edge is indicated in mm |              |
| 13 mm   | 25 mm        |
| 14 mm   | 27 mm        |
| 15 mm   | 28 mm        |
| 17 mm   | 38 mm        |
| <b>20 mm</b>  | <b>44 mm</b> |
| 22 mm   | 50 mm        |

| 3 - Tolerances |             |             |        |
|----------------|-------------|-------------|--------|
|                |             |             |        |
| Symbol         | m (mm)      | d (mm)      | s (mm) |
| <b>A</b>       | ±0.005      | ±0.025      | ±0.025 |
| <b>F</b>       | ±0.005      | ±0.013      | ±0.025 |
| <b>C</b>       | ±0.013      | ±0.025      | ±0.025 |
| <b>H</b>       | ±0.013      | ±0.013      | ±0.025 |
| <b>E</b>       | ±0.025      | ±0.025      | ±0.025 |
| <b>G</b>       | ±0.025      | ±0.025      | ±0.13  |
| <b>J</b>       | ±0.005      | ±0.05~±0.13 | ±0.025 |
| <b>K*</b>      | ±0.013      | ±0.05~±0.13 | ±0.025 |
| <b>L*</b>      | ±0.025      | ±0.05~±0.13 | ±0.025 |
| <b>M*</b>      | ±0.08~±0.20 | ±0.05~±0.13 | ±0.13  |
| <b>N*</b>      | ±0.08~±0.20 | ±0.05~±0.13 | ±0.025 |
| <b>U*</b>      | ±0.13~±0.38 | ±0.08~0.25  | ±0.13  |

\* As a rule, the sides of these inserts are as sintered. Tolerance differs with insert size. For the accuracy of Class M, refer to Table 4 at immediate right.

| 8 - Chip Breaker                            |           |
|---|-----------|
| Chip breaker according to Palbit geometries |           |
| FP  | MH        |
| ST  | RP        |
| <b>MP</b>                                   | <b>LH</b> |

| 4 - Insert Type |              |   |                           |            |
|-----------------|--------------|---|---------------------------|------------|
| Symbol          | Type         | Type of hole                              | Chipbreaker               | Shape      |
| <b>W</b>        | with hole    | Round hole / one countersink (40°~60°)    | Without chipbreaker       |            |
| <b>T</b>        | with hole    |   | Chipbreaker on one side   |            |
| <b>Q</b>        | with hole    | Round hole / double countersink (40°~60°) | Without chipbreaker       |            |
| <b>U</b>        | with hole    |   | Chipbreaker on both sides |            |
| <b>B</b>        | with hole    | Round hole / double countersink (70°~90°) | Without chipbreaker       |            |
| <b>H</b>        | with hole    |   | Chipbreaker on one side   |            |
| <b>C</b>        | with hole    |   | Without chipbreaker       |            |
| <b>J</b>        | with hole    |   | Chipbreaker on both sides |            |
| <b>A</b>        | with hole    | Round hole                                | Without chipbreaker       |            |
| <b>M</b>        | with hole    |   | Chipbreaker on one side   |            |
| <b>G</b>        | with hole    |   | Chipbreaker on both sides |            |
| <b>N</b>        | without hole | --  | Without chipbreaker       |            |
| <b>R</b>        | without hole | --  | Chipbreaker on one side   |            |
| <b>F</b>        | without hole | --  | Chipbreaker on both sides |            |
| <b>X</b>        | -            | -   | --                        | On request |

| 6 - Thickness (S)   |
|---|
| The length of the secondary cutting edge is indicated in mm |
| 08 = 8.00 mm  |
| 09 = 9.52 mm  |
| <b>10 = 10.00 mm</b>  |
| 12 = 12.00 mm   |
| 12 = 12.70 mm   |
| 13 = 13.00 mm   |
| 14 = 14.00 mm   |
| 18 = 18.00 mm   |

| 7 - Depth of Cut (ap) |
|-----------------------|
| Maximum depth of cut  |
| 20 = 2.00 mm          |
| 25 = 2.50 mm          |
| <b>35 = 3.50 mm</b>   |
| 40 = 4.00 mm          |
| 80 = 8.00 mm          |

# INSERT RANGE

## INGR

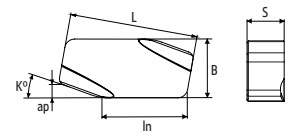

| Insert Order Code = (1) Geometry Code + (2) Grade Code                           |               |                |                | P      |        |        |        |    | M     |       |       |       |      | K       |      |      |           |      | Dimensions (mm) |      |  |  |  |  | Cutting Conditions |  |  |  |  |  |
|--|---------------|----------------|----------------|--------|--------|--------|--------|----|-------|-------|-------|-------|------|---------|------|------|-----------|------|-----------------|------|--|--|--|--|--------------------|--|--|--|--|--|
|  |               | (2) Grade Code |                | L7     | L8     | L8     | P1     | L6 |       |       |       |       |      |         |      |      |           |      |                 |      |  |  |  |  |                    |  |  |  |  |  |
| (1) Geometry Code  | ISO Reference | ANSI Reference | PH5115         | PH5125 | PH5125 | PH5228 | PH5320 | L  | In    | B     | S     | ap    | K°   | ap (mm) | Min  | Max  | fn (mm/r) | Min  | Max             |      |  |  |  |  |                    |  |  |  |  |  |
|  | 1123828       | INGR 221240-MP | INGR 221240-MP | ⊗      | ○      | ○      | ○      | ○  | 38.25 | 22.00 | 17.50 | 12.00 | 4.00 | 20      | 2.00 | 0.40 | 4.00      | 3.50 | 1.00            | 8.00 |  |  |  |  |                    |  |  |  |  |  |

## JNGF Rectangular 90° Negative

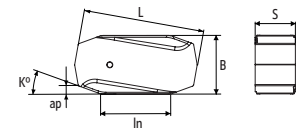

| Insert Order Code = (1) Geometry Code + (2) Grade Code                             |               |                    |                    | P      |        |        |        |    | M     |       |       |       |      | K       |      |      |           |      | Dimensions (mm) |      |  |  |  |  | Cutting Conditions |  |  |  |  |  |
|--|---------------|--------------------|--------------------|--------|--------|--------|--------|----|-------|-------|-------|-------|------|---------|------|------|-----------|------|-----------------|------|--|--|--|--|--------------------|--|--|--|--|--|
|  |               | (2) Grade Code     |                    | L7     | L8     | L8     | P1     | L6 |       |       |       |       |      |         |      |      |           |      |                 |      |  |  |  |  |                    |  |  |  |  |  |
| (1) Geometry Code  | ISO Reference | ANSI Reference     | PH5115             | PH5125 | PH5125 | PH5228 | PH5320 | L  | In    | B     | S     | ap    | K°   | ap (mm) | Min  | Max  | fn (mm/r) | Min  | Max             |      |  |  |  |  |                    |  |  |  |  |  |
|  | 1123830       | JNGF 201220-MP     | JNGF 201220-MP     | ○      | ⊗      | ⊗      | ○      | ○  | 36.90 | 20.00 | 18.00 | 12.35 | 2.00 | 20      | 1.50 | 1.00 | 2.00      | 3.50 | 1.50            | 6.00 |  |  |  |  |                    |  |  |  |  |  |
|  | 1123996       | JNGF 201220-MP SP1 | JNGF 201220-MP SP1 | ○      | ○      | ○      | ○      | ○  | 36.30 | 20.00 | 18.00 | 12.45 | 2.00 | 20      | 1.50 | 1.00 | 2.00      | 3.50 | 1.50            | 6.00 |  |  |  |  |                    |  |  |  |  |  |
|  | 1123997       | JNGF 201220-MP SP2 | JNGF 201220-MP SP2 | ⊗      | ⊗      | ⊗      | ○      | ○  | 36.50 | 20.00 | 18.00 | 12.45 | 2.00 | 20      | 1.50 | 1.00 | 2.00      | 3.50 | 1.50            | 6.00 |  |  |  |  |                    |  |  |  |  |  |
|  | 1124043       | JNGF 271220-MP     | JNGF 271220-MP     | ○      | ⊗      | ⊗      | ○      | ○  | 36.90 | 27.00 | 18.00 | 12.45 | 2.00 | 20      | 1.50 | 1.00 | 2.00      | 3.50 | 1.50            | 6.00 |  |  |  |  |                    |  |  |  |  |  |

## LNGF Rectangular 90° Negative

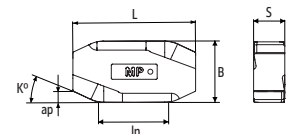

| Insert Order Code = (1) Geometry Code + (2) Grade Code                             |               |                |                | P      |        |        |        |        | M      |       |       |       |       | K    |    |         |      |      | Dimensions (mm) |      |      |  |  |  | Cutting Conditions |  |  |  |  |  |
|--|---------------|----------------|----------------|--------|--------|--------|--------|--------|--------|-------|-------|-------|-------|------|----|---------|------|------|-----------------|------|------|--|--|--|--------------------|--|--|--|--|--|
|  |               | (2) Grade Code |                | L7     | R2     | L8     | R2     | L8     | P1     | L6    |       |       |       |      |    |         |      |      |                 |      |      |  |  |  |                    |  |  |  |  |  |
| (1) Geometry Code  | ISO Reference | ANSI Reference | PH5115         | PHG115 | PH5125 | PHG115 | PH5125 | PH5228 | PH5320 | L     | In    | B     | S     | ap   | K° | ap (mm) | Min  | Max  | fn (mm/r)       | Min  | Max  |  |  |  |                    |  |  |  |  |  |
|  | 1123826       | LNGF 201035-MP | LNGF 201035-MP | ○      | ⊗      | ○      | ⊗      | ○      | ○      | 40.00 | 20.00 | 20.00 | 10.00 | 3.50 | 25 | 2.00    | 0.80 | 3.50 | 2.50            | 1.00 | 6.50 |  |  |  |                    |  |  |  |  |  |
|  | 1123827       | LNGF 201235-MP | LNGF 201235-MP | ⊗      | ○      | ○      | ⊗      | ○      | ○      | 40.00 | 20.00 | 20.00 | 12.00 | 3.50 | 25 | 2.00    | 0.80 | 3.50 | 2.50            | 1.00 | 6.50 |  |  |  |                    |  |  |  |  |  |

⊗ Stock item - First choice

⊗ Stock item

○ Available Upon Request

# INSERT RANGE

## UNGF

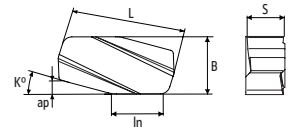

| Insert Order Code = (1) Geometry Code + (2) Grade Code                            |               |                |                | P      |        | M      |        | K  |       | Dimensions (mm) |       |       |      |         |      | Cutting Conditions |           |      |      |      |
|---|---------------|----------------|----------------|--------|--------|--------|--------|----|-------|-----------------|-------|-------|------|---------|------|--------------------|-----------|------|------|------|
|   |               | (2) Grade Code |                | L7     | R3     | R3     | P1     | L6 |       |                 |       |       |      |         |      |                    |           |      |      |      |
| (1) Geometry Code   | ISO Reference | ANSI Reference | PH5115         | PHG125 | PHG125 | PH5228 | PH5320 | L  | In    | B               | S     | ap    | K°   | ap (mm) | Min  | Max                | fn (mm/r) | Min  | Max  |      |
|  | 1123829       | UNGF 171240-MP | UNGF 171240-MP | ○      | ⊗      | ⊗      | ○      | ○  | 36.50 | 17.00           | 18.00 | 12.00 | 4.00 | 15      | 1.50 | 0.35               | 4.00      | 2.00 | 1.00 | 5.00 |

## TNMJ Triangular 60° Negative

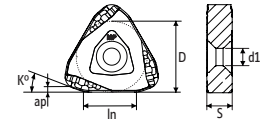

| Insert Order Code = (1) Geometry Code + (2) Grade Code                              |               |                |                | P      |        | M      |        | K      |        | Dimensions (mm) |        |       |       |       |      | Cutting Conditions |    |         |      |      |           |      |      |
|---|---------------|----------------|----------------|--------|--------|--------|--------|--------|--------|-----------------|--------|-------|-------|-------|------|--------------------|----|---------|------|------|-----------|------|------|
|   |               | (2) Grade Code |                | L7     | L8     | R3     | U5     | L8     | U5     | P1              | R3     | L6    |       |       |      |                    |    |         |      |      |           |      |      |
| (1) Geometry Code   | ISO Reference | ANSI Reference | PH5115         | PH5125 | PHG125 | PHS225 | PH5125 | PHS225 | PH5228 | PHG125          | PH5320 | D     | In    | S     | d1   | ap                 | K° | ap (mm) | Min  | Max  | fn (mm/r) | Min  | Max  |
|  | 1123838       | TNMJ 201025-MP | TNMJ 201025-MP | ○      | ○      | ⊗      | ⊗      | ○      | ⊗      | ○               | ⊗      | 28.60 | 20.00 | 10.00 | 7.00 | 2.50               | 20 | 1.00    | 0.70 | 2.50 | 3.00      | 1.00 | 5.50 |
|   | 1123843       | TNMJ 201425-MP | TNMJ 201425-MP | ○      | ⊗      | ○      | ○      | ⊗      | ○      | ○               | ○      | 28.60 | 20.00 | 14.00 | 7.00 | 2.50               | 20 | 1.00    | 0.70 | 2.50 | 3.00      | 1.00 | 5.50 |

## TNGM Triangular 60° Negative

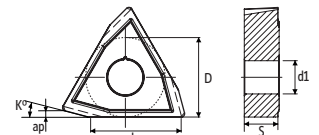

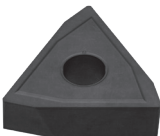
| Insert Order Code = (1) Geometry Code + (2) Grade Code                              |               |                |                | P      |        | M      |        | K  |       | Dimensions (mm) |      |      |      |         |      | Cutting Conditions |           |       |      |       |
|---|---------------|----------------|----------------|--------|--------|--------|--------|----|-------|-----------------|------|------|------|---------|------|--------------------|-----------|-------|------|-------|
|   |               | (2) Grade Code |                | L7     | L8     | L8     | N2     | L6 |       |                 |      |      |      |         |      |                    |           |       |      |       |
| (1) Geometry Code   | ISO Reference | ANSI Reference | PH5115         | PH5125 | PH5125 | PH5135 | PH5320 | D  | In    | S               | d1   | ap   | K°   | ap (mm) | Min  | Max                | fn (mm/r) | Min   | Max  |       |
|  | 1124104       | TNGM 220812-MP | TNGM 220812-MP | ○      | ⊗      | ⊗      | ○      | ○  | 19.05 | 22.00           | 8.00 | 7.96 | 1.20 | 15      | 0.70 | 0.20               | 1.30      | 14.00 | 5.00 | 18.00 |

⊗ Stock item - First choice

⊗ Stock item

○ Available Upon Request

# INSERT RANGE

## TNMM Triangular 60° Negative

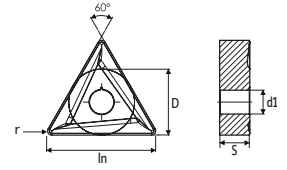

| Insert Order Code = (1) Geometry Code + (2) Grade Code |               |                           |        | P      | M      | K      | Dimensions (mm) |   |         |                |                |   | Cutting Conditions |         |     |     |           |       |       |      |
|--|---------------|---------------------------|--------|--------|--------|--------|-----------------|---|---------|----------------|----------------|---|--------------------|---------|-----|-----|-----------|-------|-------|------|
|  |               | <sup>(2)</sup> Grade Code |        | L7     | S9     | S9     |                 |   |         |                |                |   |                    |         |     |     |           | P1    | L6    |      |
| <sup>(1)</sup> Geometry Code                           | ISO Reference | ANSI Reference            | PH5115 | PHG135 | PHG135 | PH5228 | PH5320          | D   | In      | S              | d1             | r | K°                 | ap (mm) | Min | Max | fn (mm/r) | Min   | Max   |      |
|  |               |                           |        |        |        |        |                 |  | 1124102 | TNMM 441116-LH | TNMM 441116-LH | ○ | ⊗                  | ⊗       | ○   | ○   | 25.40     | 44.00 | 11.35 | 9.20 |

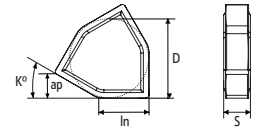

## XNGF Special 85° Negative

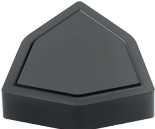

| Insert Order Code = (1) Geometry Code + (2) Grade Code |               |                           |        | P      | M      | K      | Dimensions (mm) |   |         |                |                |    | Cutting Conditions |         |     |     |           |       |      |   |
|--|---------------|---------------------------|--------|--------|--------|--------|-----------------|---|---------|----------------|----------------|----|--------------------|---------|-----|-----|-----------|-------|------|---|
|  |               | <sup>(2)</sup> Grade Code |        | L7     | L8     | L8     |                 |   |         |                |                |    |                    |         |     |     |           | P1    | L6   |   |
| <sup>(1)</sup> Geometry Code                           | ISO Reference | ANSI Reference            | PH5115 | PH5125 | PH5125 | PH5228 | PH5320          | D   | In      | S              | d1             | ap | K°                 | ap (mm) | Min | Max | fn (mm/r) | Min   | Max  |   |
|  |               |                           |        |        |        |        |                 |  | 1123837 | XNGF 150980-FP | XNGF 150980-FP | ○  | ○                  | ○       | ⊗   | ○   | 28.58     | 15.00 | 8.88 | - |

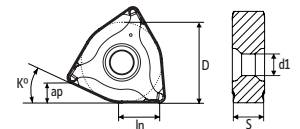
## XNMJ Special 85° Negative



| Insert Order Code = (1) Geometry Code + (2) Grade Code                              |               |                           |                | P      | M      | K      | Dimensions (mm) |   |         |                |                |      | Cutting Conditions |         |      |      |           |       |       |       |
|---|---------------|---------------------------|----------------|--------|--------|--------|-----------------|---|---------|----------------|----------------|------|--------------------|---------|------|------|-----------|-------|-------|-------|
|   |               | <sup>(2)</sup> Grade Code |                | L7     | L8     | L8     |                 |   |         |                |                |      |                    |         |      |      |           | P1    | L6    |       |
| <sup>(1)</sup> Geometry Code  | ISO Reference | ANSI Reference            | PH5115         | PH5125 | PH5125 | PH5228 | PH5320          | D   | In      | S              | d1             | ap   | K°                 | ap (mm) | Min  | Max  | fn (mm/r) | Min   | Max   |       |
|   |               |                           |                |        |        |        |                 |  | 1123835 | XNMJ 151380-MP | XNMJ 151380-MP | ○    | ⊗                  | ⊗       | ⊗    | ○    | 31.75     | 15.00 | 13.00 | 9.00  |
|  | 1123836       | XNMJ 151380-MH            | XNMJ 151380-MH | ○      | ⊗      | ⊗      | ⊗               | ○   | 31.75   | 15.00          | 13.00          | 9.00 | 8.00               | 25      | 3.00 | 1.00 | 6.50      | 6.00  | 4.00  | 12.00 |

⊗ Stock item - First choice

⊗ Stock item

○ Available Upon Request

# INSERT RANGE

## XNGJ Special 85° Negative

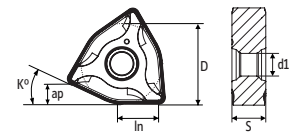

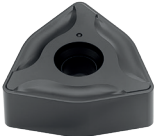
| Insert Order Code = (1) Geometry Code + (2) Grade Code                            |               |                           |                | P      |        | M      |        | K  |       | Dimensions (mm) |       |      |      |         |      | Cutting Conditions |           |      |      |       |  |
|---|---------------|---------------------------|----------------|--------|--------|--------|--------|----|-------|-----------------|-------|------|------|---------|------|--------------------|-----------|------|------|-------|--|
|   |               | <sup>(2)</sup> Grade Code |                | L7     | L8     | L8     | P1     | L6 |       |                 |       |      |      |         |      |                    |           |      |      |       |  |
| <sup>(1)</sup> Geometry Code  | ISO Reference | ANSI Reference            | PH5115         | PH5125 | PH5125 | PH5228 | PH5320 | D  | In    | S               | d1    | ap   | K°   | ap (mm) | Min  | Max                | fn (mm/r) | Min  | Max  |       |  |
|  | 1123834       | XNGJ 151380-RP            | XNGJ 151380-RP | ○      | ○      | ○      | ⊗      | ○  | 31.75 | 15.00           | 13.00 | 9.00 | 8.00 | 25      | 3.00 | 1.00               | 6.50      | 6.00 | 4.00 | 12.00 |  |

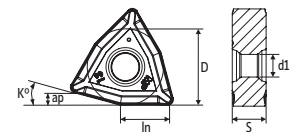

## WNGJ Special 75° Negative

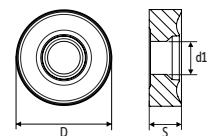

| Insert Order Code = (1) Geometry Code + (2) Grade Code                              |               |                           |                | P      |        | M      |        | K  |       | Dimensions (mm) |      |      |      |         |      | Cutting Conditions |           |      |      |       |  |
|---|---------------|---------------------------|----------------|--------|--------|--------|--------|----|-------|-----------------|------|------|------|---------|------|--------------------|-----------|------|------|-------|--|
|   |               | <sup>(2)</sup> Grade Code |                | L7     | L8     | L8     | P1     | L6 |       |                 |      |      |      |         |      |                    |           |      |      |       |  |
| <sup>(1)</sup> Geometry Code  | ISO Reference | ANSI Reference            | PH5115         | PH5125 | PH5125 | PH5228 | PH5320 | D  | In    | S               | d1   | ap   | K°   | ap (mm) | Min  | Max                | fn (mm/r) | Min  | Max  |       |  |
|  | 1124041       | WNGJ 130950-MP            | WNGJ 130950-MP | ○      | ⊗      | ⊗      | ⊗      | ⊗  | 22.23 | 13.00           | 9.56 | 7.93 | 5.00 | 15      | 3.00 | 0.50               | 5.00      | 6.00 | 3.00 | 11.00 |  |

## RNMX Round R° Negative



| Insert Order Code = (1) Geometry Code + (2) Grade Code                              |               |                           |                | P      |        | M      |        | K      |        | Dimensions (mm) |    |       |       |    |    | Cutting Conditions |      |       |           |      |       |  |
|---|---------------|---------------------------|----------------|--------|--------|--------|--------|--------|--------|-----------------|----|-------|-------|----|----|--------------------|------|-------|-----------|------|-------|--|
|   |               | <sup>(2)</sup> Grade Code |                | L7     | R3     | V8     | R3     | P1     | V8     | L6              |    |       |       |    |    |                    |      |       |           |      |       |  |
| <sup>(1)</sup> Geometry Code  | ISO Reference | ANSI Reference            | PH5115         | PHG125 | PHS228 | PHG125 | PHS228 | PHS228 | PHS320 | D               | In | S     | d1    | ap | K° | ap (mm)            | Min  | Max   | fn (mm/r) | Min  | Max   |  |
|  | 1123831       | RNMX 381200-MP            | RNMX 381200-MP | ○      | ⊗      | ○      | ⊗      | ⊗      | ○      | 38.10           | -  | 12.70 | 13.00 | -  | -  | 4.00               | 2.00 | 8.00  | 2.00      | 1.00 | 4.00  |  |
|   | 1123832       | RNMX 5018M0-MP            | RNMX 5018M0-MP | ○      | ⊗      | ○      | ⊗      | ⊗      | ○      | 50.00           | -  | 18.00 | 12.70 | -  | -  | 6.00               | 2.00 | 12.00 | 3.50      | 2.50 | 6.50  |  |
|  | 1123833       | RNMX 5018M0-RP            | RNMX 5018M0-RP | ○      | ○      | ⊗      | ○      | ⊗      | ⊗      | 50.00           | -  | 18.00 | 12.70 | -  | -  | 6.00               | 2.00 | 12.00 | 6.00      | 4.00 | 10.50 |  |

⊗ Stock item - First choice

○ Stock item

○ Available Upon Request



PalbitUSA.com



BAR PEELING  
Tool Solutions



\* RNMX-RP | Actual Size

U.S. Partner:



Precision Products

15 Merrigan Way | South Deerfield, MA 01373

413-350-5200 | PilotPrecision.com

ISO 9001:2015



SINCE 1916